

# ***VE workshop at McGill University: benefits for students and industry***

**Vince Thomson**

Werner Graupe Professor of Manufacturing Automation

Department of Mechanical Engineering

McGill University

**CSVA 2008 Conference: VA/VM Creating Value**



SOCIÉTÉ CANADIENNE DE L'ANALYSE DE LA VALEUR  
CANADIAN SOCIETY OF VALUE ANALYSIS



# Outline

- Description of the VE Workshop
- Industry benefits
- Student benefits
- Examples of projects
- Pedagogical lessons

# ***McGill VE Workshop Objectives***

- To provide a forum for a high degree of interaction between students and engineers from industry.
- To train students and company participants to use a systematic, optimization technique for problem solving: value engineering.

# ***McGill VE Workshop Description***

- The Workshop has operated for 36 years and has done 206 VE projects.
- The workshop is taught by a Certified Value Specialist (Lucie Parrot) as Module I of VE training, a professor and a practicing engineer (Louis L'Homme).
- To assist industry, the workshop has only 5 sessions for teaching VE methodology and group problem solving.
  - Sessions are from 1:30 to 9:30 p.m. on 5 Mondays during the fall semester.
  - The five sessions follow a five-step job plan.
- Due to the long sessions, coffee and doughnuts and an evening meal are served!

# ***McGill VE Workshop Description***

- Teams are composed of 5 students and 1-2 company representatives.
- Students and companies act as a team and meet at other than class times.
- Usually there is a company visit to see the problem first-hand.
- Instruction during each session is about 2 hours with teams doing their projects the rest of the time.
- For grading,
  - 60 % is based on the final presentation and report
  - 40% is based on an evaluation by industry participants.

# ***McGill VE Workshop Outcomes***

- Formal presentations of project results are made to all the sponsor companies at a hotel near the university.
- Companies receive a final report containing
  - a description of the problem,
  - the results of the value engineering analysis,
  - a set of alternative solutions to the problem, and
  - recommendations for action.

# ***Industry Benefits***

- Training in Value Engineering methodology
- Exposure between future and practicing engineers
  - Companies hire many of the students.
  - Companies contribute to the education process.

## **Value obtained**

- For the year 2000, the combined five-year return for six projects was \$15 million, accomplished with a total investment of \$500,000. This represents a return on investment of 30:1.
- From surveys of companies, the implementation rate is about 50% of the recommendations.

# ***Student Benefits***

- Obtain a VE Mod I certificate
- Learn the value engineering methodology
- Develop analytical and investigative skills
- Obtain experience on a real world problem
- Learn current, industrial standards of engineering professionalism
- See the business and technical operations of a company

# *Typical Projects*

- New designs (redesigns) for products, manufacturing processes, and business services
- Over a three year period
  - 14 product designs (5 new designs, 9 redesigns)
  - 4 manufacturing processes (1 new process, 3 existing processes)

# 2007 Projects

123 Certification Inc.

- Design optimization of a portable welding simulator

Group Tekdata Inc.

- Automated storage and retrieval system for metal sheet

Jitech

- Gantry robot for the fabrication of structural steel

McGill VERT

- Value increase for an electric snowmobile

Rolls-Royce Energy

- Cost reduction and design for manufacture for a Trent engine flow straightener

# ***Gantry robot for the fabrication of structural steel (Jitech)***

- Jitech engineers and cuts steel beams for structures.
- Present automated systems only work for 2D shapes.
- Project objective was to create a fully automated, robotic system for 3D cutting of steel box beams, cylindrical beams and I-beams.

## **Concept**

- A 3D model of a beam is created by laser scanning.
- The scanned model is compared to the CAD model.
- The system makes precise cuts into the beam by adjusting discrepancies between the two geometries.

# ***Gantry robot for the fabrication of structural steel***

- The VE team specified a two armed gantry robot with a 3D scanner and tool changer.
- Tools included a plasma cutter and welder.
- The system cuts the necessary holes and notches into the surfaces of the steel beams, and then, welds brackets necessary for final assembly.

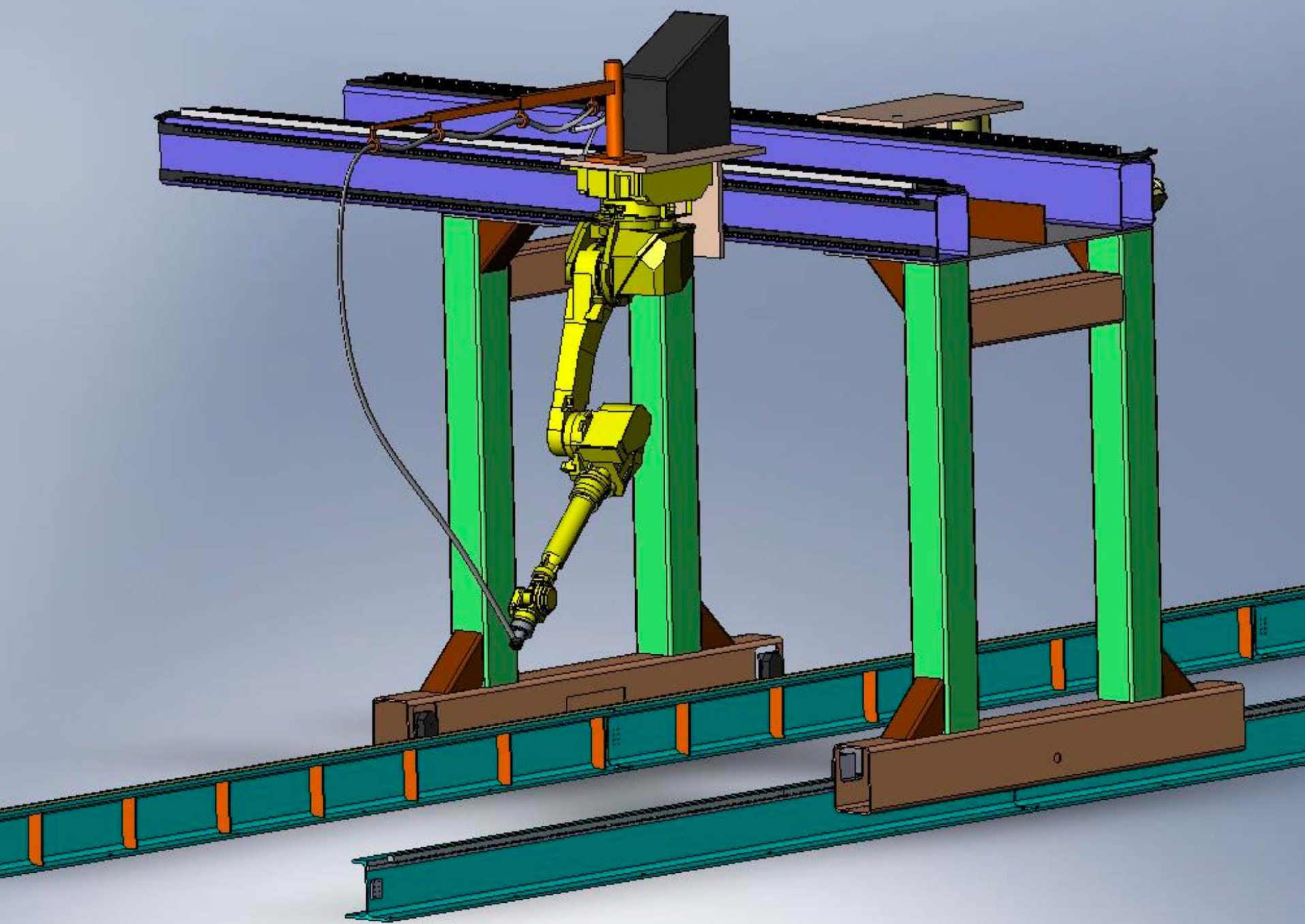

# ***Discussion***

- One of the benefits of the Value Engineering Workshop is having students and company representatives work together. Students are exposed to
  - the level of professionalism required for performing projects
  - specific engineering methods used in product and process development.

# ***Discussion***

- The Value Engineering Workshop is organized as 5 sessions of 8 hours.
  - It satisfies the time requirement for university courses.
  - The small number of sessions makes it easier for companies to attend.
  - The 5 sessions align well with the value engineering job plan.

# ***Discussion***

- The McGill Value Engineering Workshop is a certified course.
  - Participation is attractive to company employees since certification adds to their credentials.
  - It is attractive to students since it makes them more marketable when they graduate.

# ***Discussion***

- Instructors visit all the groups several times during sessions to make certain that they understand and are following the VE methodology.
- They also assist at the research stage to find alternative solutions for problems: different mechanisms, material selection, manufacturing processes, and analyses like stress and heat transfer.
- Participation is limited to 6 groups of 5 students each.

# ***Discussion***

- A course highlight is the formal presentation to peers and company representatives.
  - It emphasizes the persuasion element of improvement projects.
  - Students make a trial presentation the week before the formal presentation.
  - They get feedback from the three instructors on how to improve the content, the visualization, and the delivery of their presentation.

# ***Discussion***

- One of the significant benefits of the Value Engineering Workshop is learning the value engineering methodology.
- The combination of function and cost analysis has proven powerful over time for producing organized thinking about problems and solutions.
- Due to their engineering background, the students learn the VE methodology and apply it relatively easily.
- The methodology works well for class projects.
- Many graduates use VE during their careers.

# Conclusion

- Over the past 36 years, the McGill University Value Engineering Workshop has been very successful in providing
  - training for students and company representatives in value engineering,
  - significant value with solutions to company problems,
  - a unique opportunity for interaction between students and industry.

# *Finally*

- Representatives from the CSVA judge student presentations and give the SCAV-CSV A Pfeiffer-Wales Award for Best Presentation.
- In 2007, presentations were made at the SCAV-CSV A conference in Montreal. The award was shared by the two teams, who worked on the 123 Certification Inc. and McGill VERT projects.
- Positive comments were made by judges and conference participants on the high level of professionalism and enthusiasm shown by the students.